

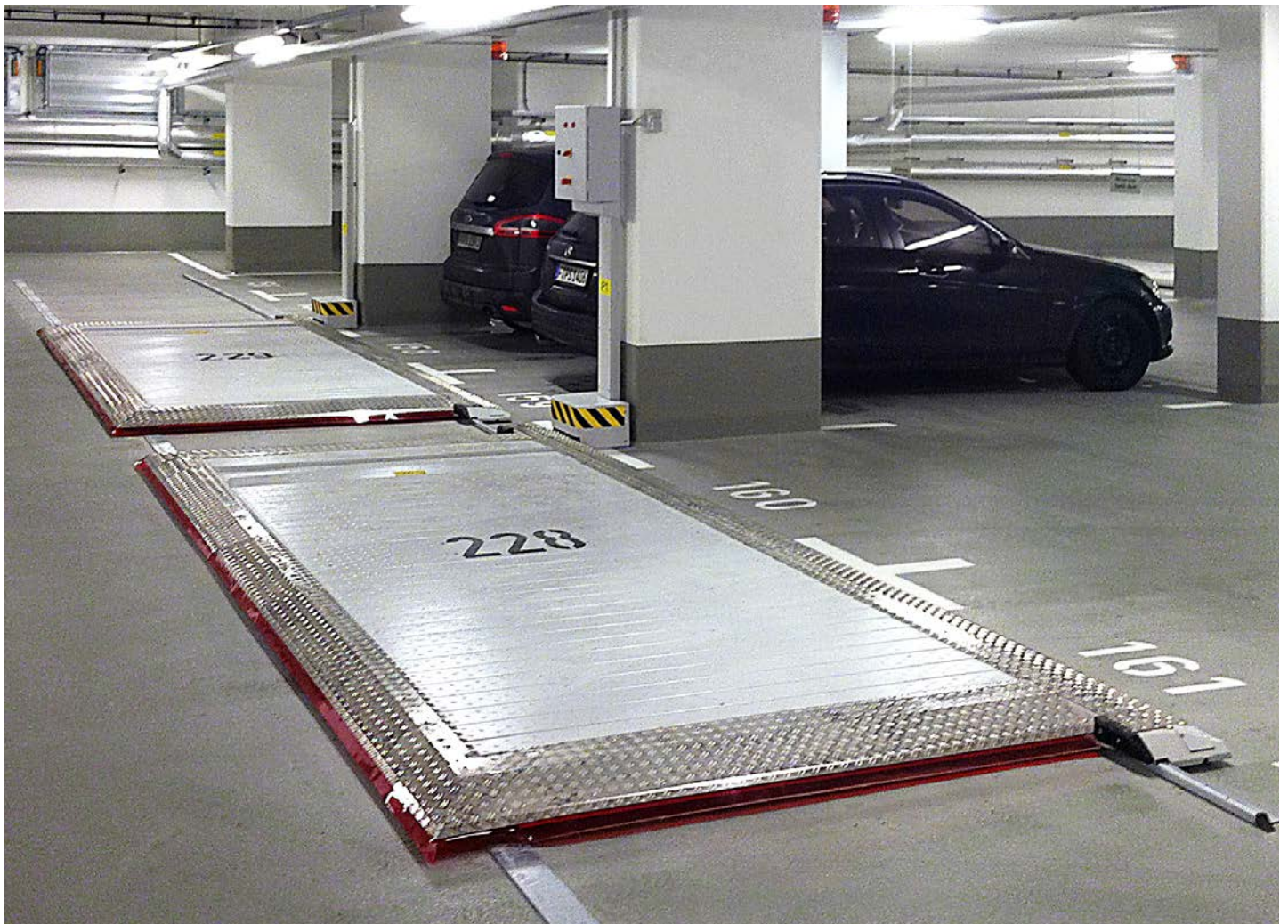

## LONGITUDINAL SLIDING PLATFORMS N6101-N6201

THE IDEAL SOLUTION TO OPTIMIZE SPACE IN GARAGES



### SHORT DESCRIPTION

- MAXIMAL USE OF AVAILABLE SPACE BY EMPLOYING PLATFORMS ON DRIVING LANES
- MODULAR CONSTRUCTION: DEPENDING ON THE CONDITIONS ON SITE, IT CAN BE POSSIBLE TO ADD SEGMENTS AT WILL
- LOAD PER PARKING SPACE: STANDARD 2.000 KG  
OPTIONAL UP TO 2.300 KG OR 2.600 KG

### APPLICATION

FOR INTERIORS AND EXTERIORS  
ONE AND MULTI-FAMILY DWELLINGS  
HOTELS AND OFFICE BUILDINGS  
CONDOMINIUMS  
COMMERCIALS  
FOR PERMANENT USERS ONLY

## N6101 - TECHNICAL DATA

### LONGITUDINAL SLIDING PLATFORM N6101 FOR 1 CAR

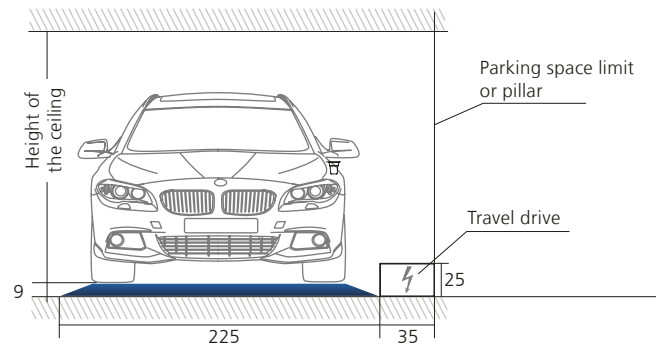
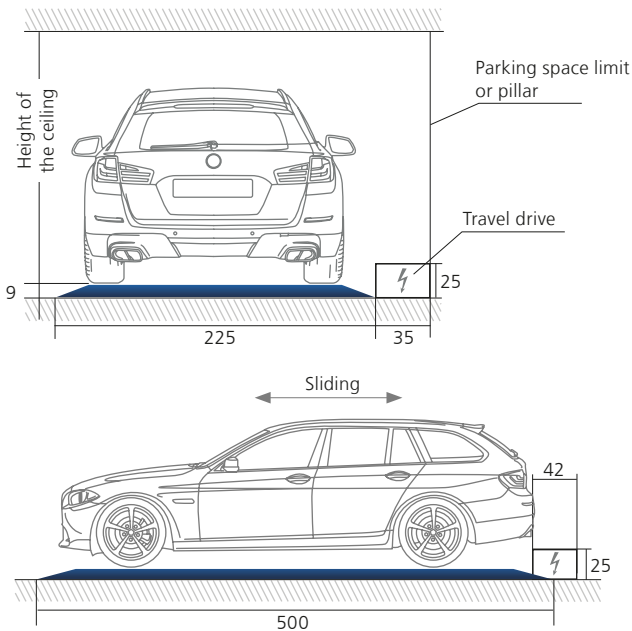

The platforms are guided by rails and are placed in front of traditional parking spaces.

By pressing a button the platforms are slid in dead man's control by chain, in order to allow driving towards and out of the traditional parking spaces.

Warning lights flash during the sliding process.

Load per parking space: max. 2.000kg, wheel load: max. 500kg. Optionally up to 2.300 kg or 2.600kg, wheel load max. 650kg. Heavier cars shall not drive over the sliding platforms.

Concrete: min. 18, C25, floor evenness acc. to DIN 18202 tab. 3, line 3.

All measurements are in cm.

Non-occupied parking pallets can be traversed at walking speed subject to observance of the max. weight of vehicle.

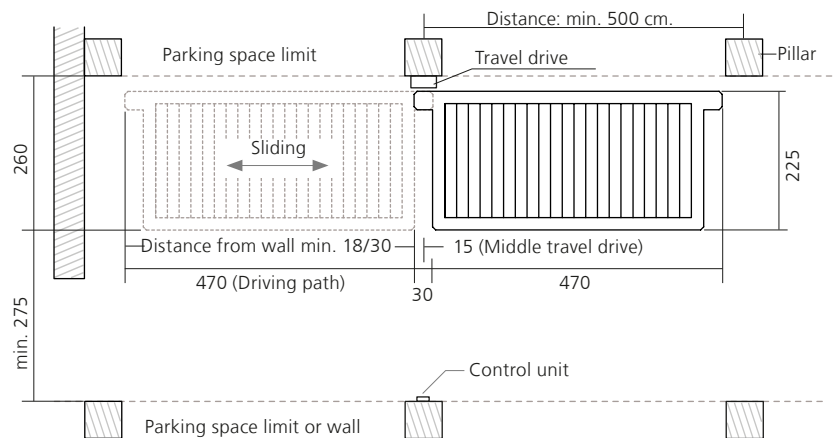

CAR LENGTH	CAR WIDTH	CAR HEIGHT	CAR WEIGHT	WHEEL LOAD	* Car weight: optionally up to 2.300 kg or 2.600 kg upon request.
500	190	10 cm shorter than the ceiling height	2000*	500	

#### VEHICLE DATA: STANDARD CAR

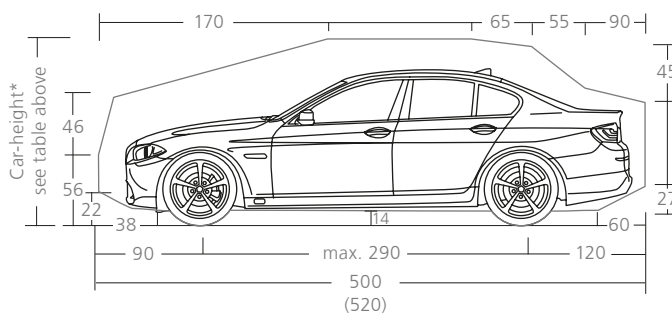

#### VEHICLE DATA: STANDARD ESTATE CAR

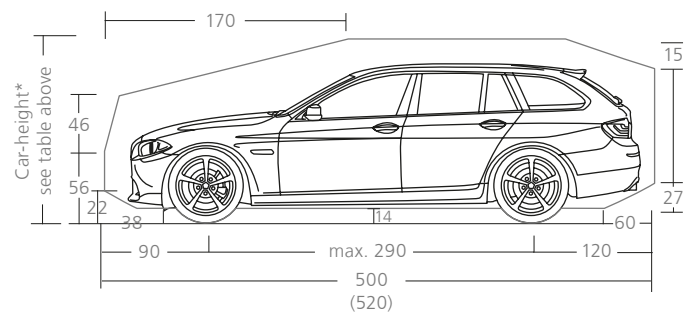

## N6201 - TECHNICAL DATA

### LONGITUDINAL SLIDING PLATFORM N6201 FOR 2 CARS

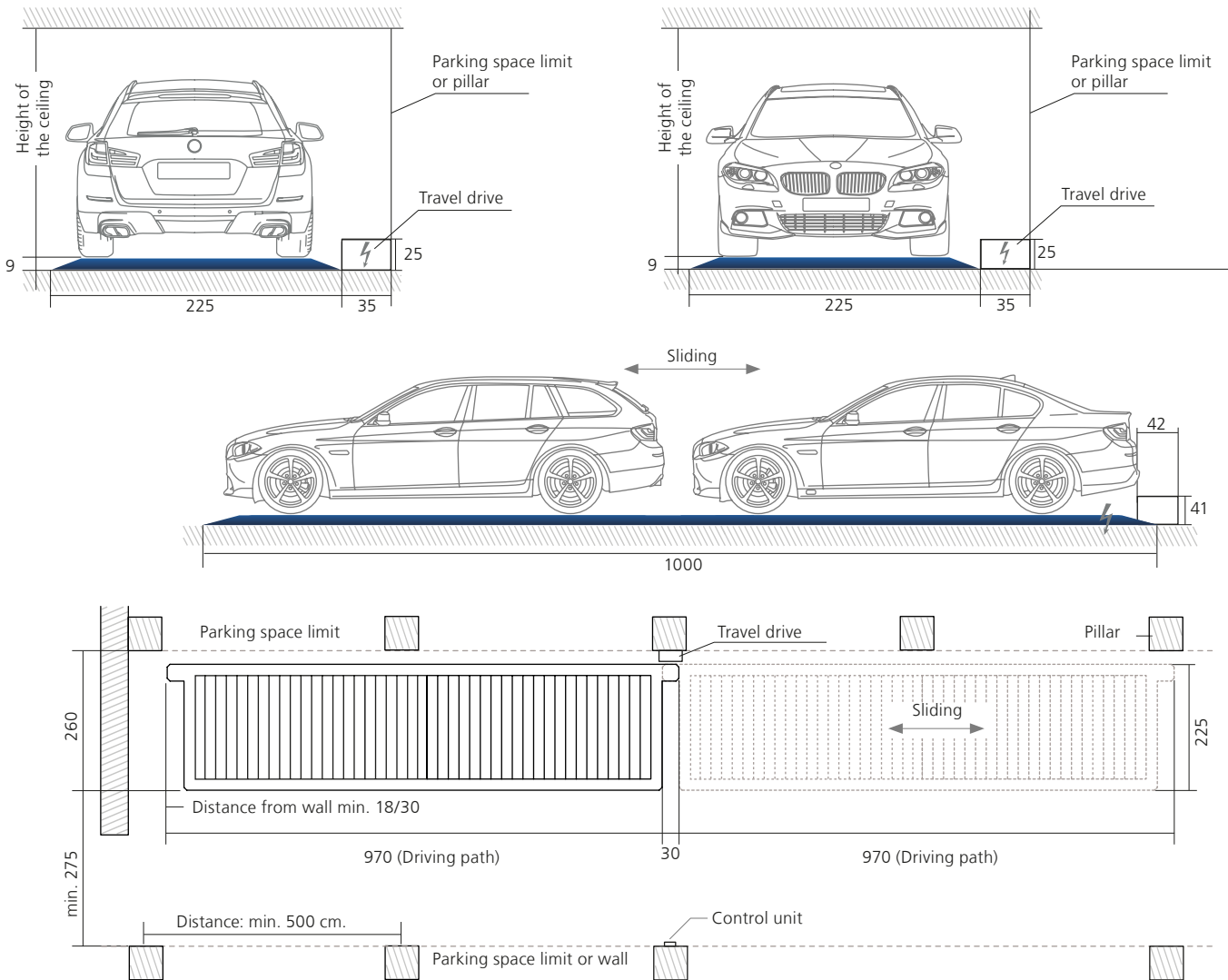

CAR LENGTH	CAR WIDTH	CAR HEIGHT	CAR WEIGHT	WHEEL LOAD	* Car weight: optionally up to 2.300 kg or 2.600 kg upon request.
500	190	10 cm shorter than the ceiling height	2000	500	

Note: The measurements above are valid for one car. For the N6201 - double sliding platform - the measurements are to be doubled.

#### VEHICLE DATA: STANDARD CAR

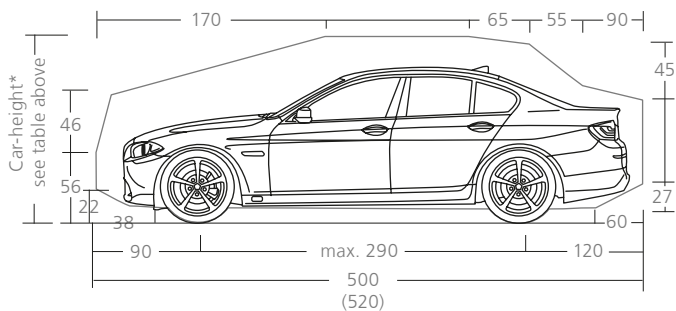

#### VEHICLE DATA: STANDARD ESTATE CAR

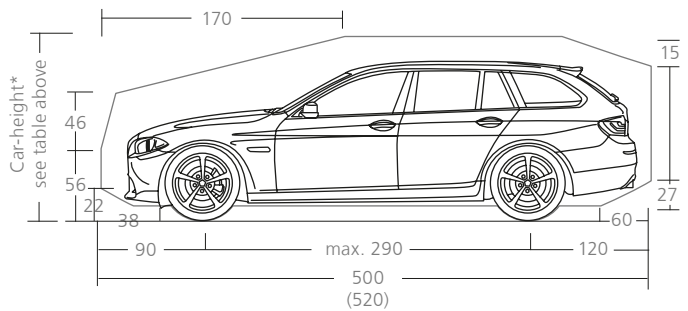

## SAFETY DISTANCES AND TOLERANCES TO FLOOR EVENNESS

### COMPLIANCE WITH THE SAFETY DISTANCES ACC. TO DIN

Platform interlinking and safeguard to be conducted acc. to specific building and safety requirements, see DIN EN 14010, 5.8-5.9.

Distance from the side wall:

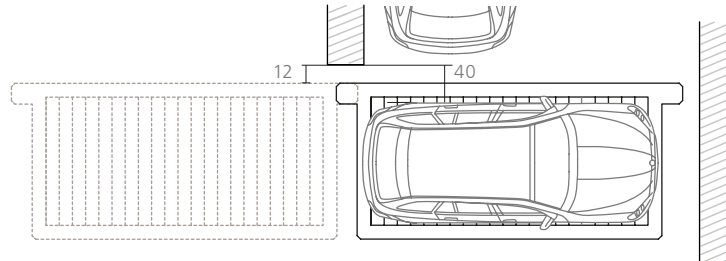

Excerpt from DIN EN 14010:  
2009-12, 5.9: „Safety of machinery - Equipment for power driven parking of motor vehicles“

Distance from the back wall and between cars:

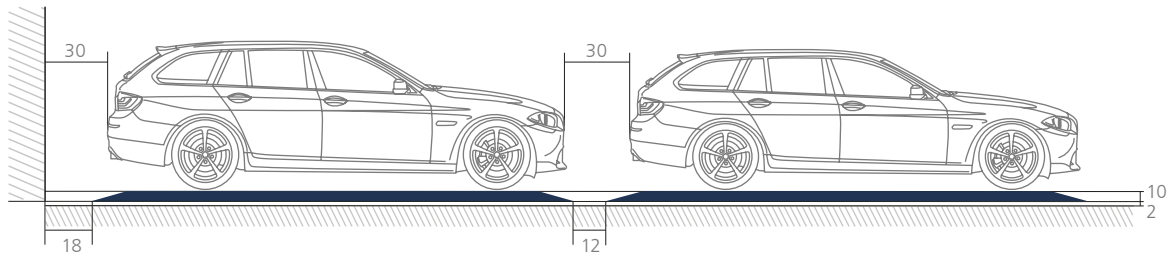

Abstract from DIN EN 14010: 2009-12, 5.9: „Safety of machinery - Equipment for power driven parking of motor vehicles“

If the above mentioned safety distances cannot be fulfilled due to the building shape, or the possibility of controlling the parking facility from the control unit is impeded, then the danger areas between moving parts or moving and fixed parts in a range from 0.3 m up to 1,5 m above the ground must be protected by employing safety devices, such as sensitive contact edges, light barriers, and laser scanners. This is not valid for buffers and coupling devices.

### FLOOR EVENNESS TOLERANCES

Acc. to DIN EN 14010, the max. safety distance between the lowest part of the parking platform and the floor shall not be more than 2cm. Therefore it is necessary to ensure that the floor features the necessary evenness (suggested material: screed). Please comply with the driving lane's floor evenness tolerances acc. to DIN 18202, tab. 3, line 3.

Excerpt from DIN 18202, table 3:

COLUMN	1	2	4	10	13	14
GROUP	APPLICABLE TO	Position deviations (limit values), in mm, for distances between measuring points, in m, up to				
		0,1	1	4	10	15
2	unfinished upper surfaces of floors, subfloors and concrete bases subject to more stringent requirements (e.g. to receive floating screed, industrial floors, tile flooring and bonded screed), and finished surfaces for minor purposes (e.g. in storerooms or basements)	5	8	12	15	20
3	finished floors (e.g. screed as wearing courses or screed to receive a flooring, trowelled or bonded floorings)	2	4	10	12	15

## REQUIREMENTS AND ELECTRICAL INSTALLATION

### REQUIREMENTS

Acc. to German MGA VO (general garage regulation) - the installation of longitudinal sliding platforms is only permissible when the following prerequisites are fulfilled:

- The minimal remaining driving lane width next to the sliding platforms must be at least 275 cm.
- It is not allowed to install sliding platforms in front of power driven parking systems.
- If the traffic in the driving lane comes from both directions, then through-going traffic is not allowed.
- The longitudinally sliding platforms can be roundly traversed at walking speed.
- The clear height in the walkable areas must be at least 210 cm. Please mind heating and ventilating systems, ceiling joists and other diverse building parts. Note: the parking platform is approx. 9 cm high.
- On a total length of 40 m it is possible to install max. a group of 5 platforms, in case their sliding path overlaps. In this case the control elements shall not be positioned farther than 10 m from a possible contact point between 2 platforms.

### ELECTRICAL INSTALLATION

#### Services covered by the NU-SPACE Company

POS.	QTY.	DESCRIPTION
1	1x	Electrical power unit 0,75 kW, 400 V, 2,1 A, IP 44
2	1x	Control line 5x1 mm <sup>2</sup> Ölflex classic 110
3	1x	Motor line 7x1,5 mm <sup>2</sup> Ölflex classic 110
4	1x	Switch cabinet IP 44
5	1x	Control line 4x1 mm <sup>2</sup> Ölflex classic 110
6	1x	Flashlight with self-monitoring
7*	1x	1 platform: Control line 5x1 mm <sup>2</sup> 2 platforms: Control line 7x1 mm <sup>2</sup> 3 platforms: Control line 9x1 mm <sup>2</sup> 4-more platforms: Control line 12x1 mm <sup>2</sup>
8	1x	Control unit

\* Data in position 7 refer to the amount of platforms connected with one only control unit.

#### Installation diagram

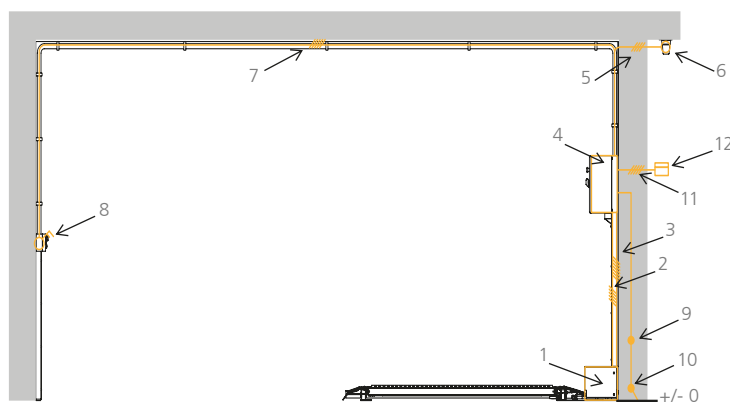

Positions 1 to 8 are included in the scope of delivery of the NU-SPACE company, unless otherwise agreed in the offer or in the contract.

The control unit is normally installed in the driving lane on the opposite side of the platforms.

#### Services to be provided by the customer

POS.	QTY.	DESCRIPTION	POSITION
9	1x	Blade fuse or circuit breaker 3x 20A, slow acc. to DIN VDE 0100 part 430	in the supply line
10	1x	Equipotential bonding according to DIN EN 60204 from the connector of the foundation earth electrodes to the system	
11	1x	Supply line 5x 2,5mm <sup>2</sup> (3 PH + N + PE) with marked leads + protective earth conductor	to the switch cabinet
12	1x	Electricity meter	

## STANDARD FEATURES

Included in the scope of delivery

### COMPONENT PARTS

Longitudinal sliding platform with 2 rails, 4 groups of 2 rollers at the platform corners, electrical power unit, with control element, in dead man's control.

### DRIVING SHEETS

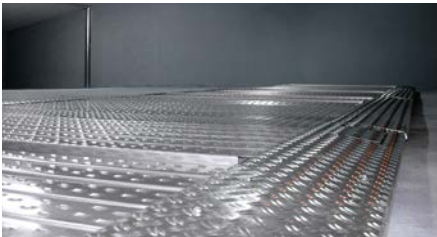

Platforms with side carriers and driving sheets made of trapezoidal sheet.

### SYSTEM'S MEASUREMENTS

Designed for:

Parking space length: 500 cm

Parking space width: 217 cm

System width incl. power unit: 260 cm

Load per parking space up to 2.000 kg.

### CONTROL UNIT

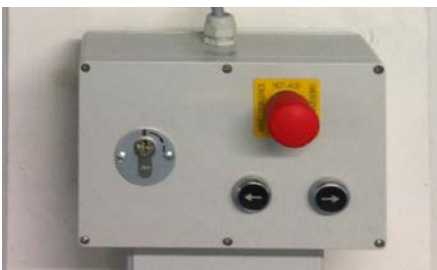

Key switch with buttons for the sliding direction and emergency-off, in dead man's control, with brief operating instructions fastened on the wall and cabling to the power unit.

Control unit measurements: 24x12x9 cm.

### ABOVE-GROUND POWER UNIT

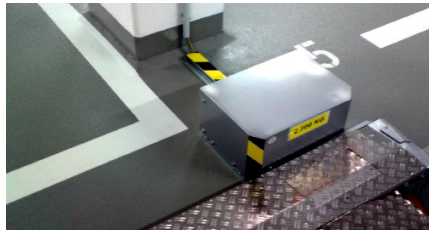

Very compact power unit with chain drive. With high power force 0,75 kW.

No holes in the ground are necessary for the fastening of the unit.

Power unit measurements: 42x35x25 cm.

### POSITIONING OF THE POWER UNIT AND SWITCH CABINET



the power unit must be placed in the middle of the total platform's driving path, preferably at a column or in front of a building pillar.

The switch cabinet is fastened above the power unit and cabled to it.

Switch cabinet's measurements:

for 1 system: 30x40x21 cm

for 2 systems: 40x50x21 cm

for 3 to 5 systems: 50x50x21 cm.

### DOCUMENTATION

Brief operating instructions (fastened to the control unit), documentation (test book and operating instructions).

### NOTE

We suggest periodical maintenance, care and cleaning. Take advantage of NU-SPACE maintenance agreements.

### CORROSION PROTECTION

C2-Line

Recommended only for regions with small or no snowfall and low humidity levels.

### SLIDING RAILS



Detail of the platform on the driving rail

The guide rail and the driving rail are bolted directly to the floor of the garage during the installation of the parking platform.

Attention: for the installation of several longitudinal sliding platforms in one row please mind that it is allowed to connect to one control unit only the platforms that are within a radius of max. 20 m (please see DIN EN 14010, article 5.8.4.2), so that it is possible to control the whole movement of the platforms from the control element's position.

### ELECTRICAL INSTALLATION

For a list of services and interfaces please see the respective table in this brochure.

## OPTIONS AND EXTRA EQUIPMENT

Available upon request - here are illustrated only some examples...

### NOTE

We suggest periodical maintenance, care and cleaning. Take advantage of NU-SPACE maintenance agreements.

### CAR WEIGHT

Load per parking space up to 2.300 kg or max. 2.600 kg.

### CORROSION PROTECTION

C3-Line for higher corrosion protection. the frame is powder coated. The driving sheet is strip galvanised and powder coated. Frame covering in aluminium-bulb plates.

### ADDITIONAL FLASHLIGHT



The flashlight signals that the system is running and therefore gives more safety to the user as well as to other people next to the system. It is possible to use one flashlight for up to 2 systems.

### POWER UNIT WITH SAFETY ARCH



Optional in case the power unit cannot be placed at a building pillar.

### EXTRA SHEET CHAIN GUIDE

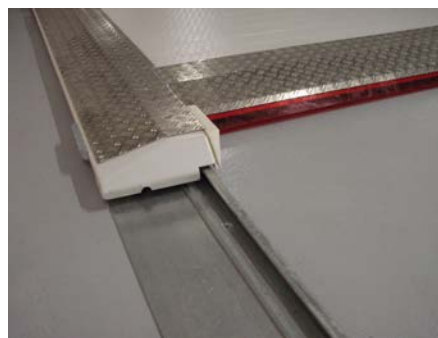

Extra sheet is placed next to the chain guide. It is a protection against sediment (result of the circulating transport chain)

### SELECTABLE BASIS POSITION

In case the driving path of one platform is in the middle of a curve or it obstacles driving through the driving lane, the control element of the system will be set to only allow retrieval of the key when the system has reached a particular end position.

### LIGHT BARRIERS - IF DANGER OF CRUSHING OR CUTTING EXISTS

(Note: according to the building situation this position could be mandatory)  
Light barriers to electrically control the system for maximum operational safety.

### PLATFORM INTERLINKING

It is possible to interlink up to 5x N6101 single platforms or up to 3x N6201 double platforms, as long as the platforms are closely spaced.

### OTHER

In case the floor is made of melted asphalt instead of concrete, additional expenses will occur. The exact amount of these expenses can only be defined case by case.

## SERVICES TO BE PROVIDED BY THE CUSTOMER AND PLANNING INDICATIONS

During the planning phase please observe and comply with the following notes!

All dimensions in cm. All dimensions are minimum dimensions. Advice for planning and tendering: Generally masonry and concrete works are to be conducted according to the German norm VOB/C (DIN 18330 and DIN 18331). The mentioned norm points the tolerances that are to be fulfilled according to DIN 18202. In this norm the maximum exceedance and short-fall of the nominal size are defined. The nominal size should be planned in order to meet the minimum dimensions necessary for the parking system.

### SERVICES TO BE PROVIDED BY THE CUSTOMER

#### Parking spaces' numeration

For the allocation of the parking spaces we suggest our customers to numerate the parking spaces.

#### Noise abatement measures

The compliance with these measures must be carried out by the customer acc. to norm DIN 4109: „Sound insulation in building construction“.

#### Lighting

To be carried out by the customer acc. to DIN 67528: „Lighting for parking areas and indoor car parks“.

#### Installation requirements

The compliance with installation requirements acc. to quotation.

#### Electrical installation

Prior to starting the assembly the customer must provide a lockable main control switch out of the system close to the power unit. Electrical services to be provided by the customer acc. to this brochure's specification.

#### Building permit

The customer must apply for and get the required permits in order to allow the installation of the parking system.

#### Control unit

The customer must make sure that a plain surface of (L x W) 50 cm x 20 cm for the installation of the control unit is directly close to the power unit and out of the platforms' moving area.

#### Wall openings

In case of partition walls the customer must realise a 10 cm x 10 cm wall opening for hosting hydraulic and electrical cables.

#### Fire protection

The customer must agree upon the fire protection requirements and the required measures with the local fire department and realise them.

#### Access to the garage

Prior to installation's begin the entrance of the garage must be accessible even with a forklift truck.

### PLANNING INDICATIONS

#### Parking space width and driving lanes

While planning the parking space and driving lane dimensions please observe and comply with the local/national prescriptions for the garages' construction. For more parking comfort we suggest you to plan parking spaces of at least 250 cm width.

#### Group of users

Our parking systems are conceived for a permanent and instructed group of users.

#### Maintenance and care

We suggest a timely conclusion of a maintenance agreement. We suggest also to perform maintenance, care and cleaning at regular time intervals.

#### EG-Machinery directive

Our parking systems comply with the EG-Machinery directive and are CE certified according to the norm DIN EN 14010.

#### Ramps' inclination

Ramps leading to garages shall not have more than 15% inclination.

#### Modifications

The company NU-SPACE reserves the right to make dimensional, design and technical modifications.